

Remote Controller Manual

Wired Remote Controller
ATC-080022

Installation

1. Look for a location which has a constant temperature in the house and is not near the door entry or air conditioning outlet. (see example on figure 1).

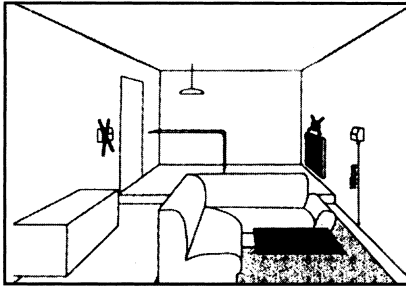

FIG. 1

2. **WARNING!!!** You must remember to turn off your main power switch before installing the thermostat.

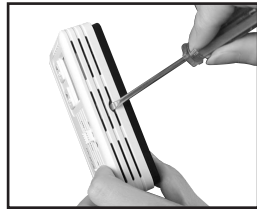

FIG. 2

3. Disconnect the front cover by pressing a hook on the top of the front cover with a screw driver. (see figure 2). Remove the front cover with your hand holding both sides of the cover (see figure 3).



FIG. 3

4. Untie the screw to remove the protection cover. (see figure 4-1)

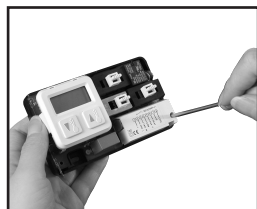

FIG. 4-1

5. Mount the base with the wire through the holes of the base and tighten the base with screws on the wall (see figure 4-2).

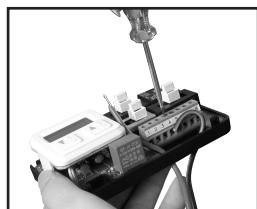

FIG. 4-2

6. Install the wires into the terminal block with a screw driver to tighten the screw on top of terminal block (see figure 5). Before you install the wires, you must check your system wiring diagram. If your system is other than this type please check with your local dealer or consult with a professional electrician.
7. Put the front cover back on the base and make sure that the hooks on the base are locked with the front cover.
8. You can turn on the main power switch for operation.

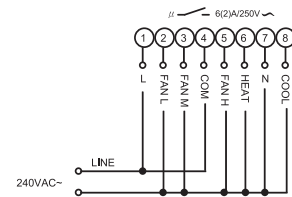
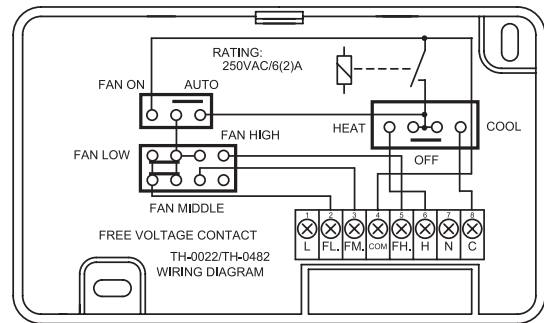
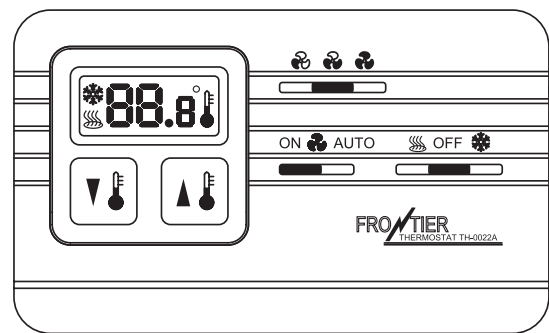
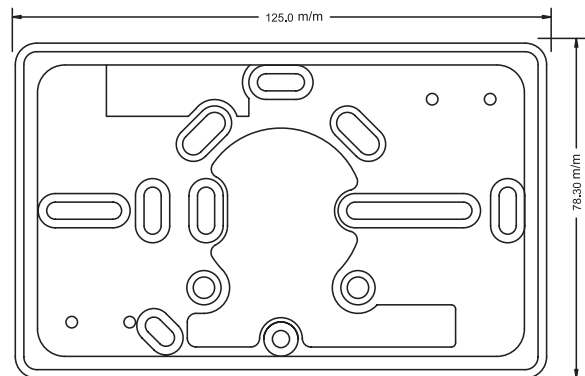

FIG. 5



BACK PLATE



Setting & Operating:

1. Press either ▼ or ▲ and LCD display will show a flashing temperature with "Heat On" symbol (🔥) and "Temperature Set" symbol (🌡️).
2. Press again either ▼ or ▲ to set a desired temperature. Every press on ▲ will increase 1°C and every press on ▼ will decrease 1°C.
3. When you complete setting your desired temperature, please wait for 15 seconds until the LCD display stops flashing. Then, the thermostat starts to operate and the LCD display on the front panel of this unit shows room temperature with "Heat On" symbol (🔥) until the temperature reaches your set temperature and then the unit will in operate to maintain the preset temperature.



ALPICAIR

FEEL COOL

WWW.ALPICAIR.COM